

Philadelphia Scientific® Stealth Watering System™

Installation & Operation



Stealth Slim Valve

Stealth Valve



Philadelphia Scientific®
industrial battery innovation

What does a Stealth Watering System™ Kit include?

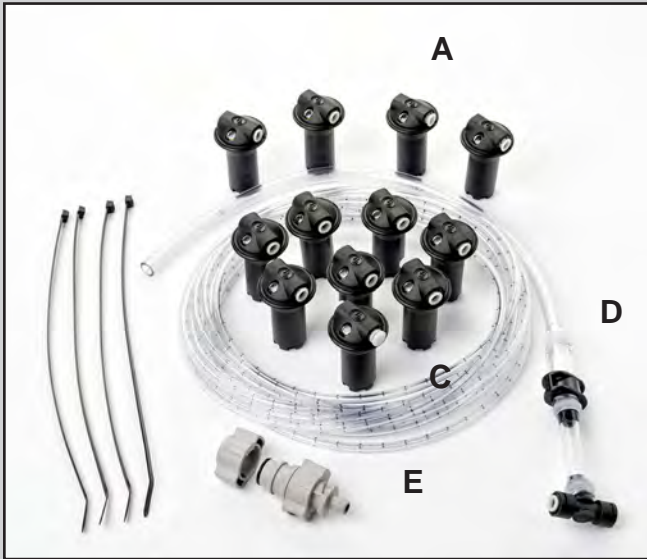

- This pack contains:
- # x Stealth valves (A)
 - 2 x Stealth valves With End Plugs (B)
 - 1 x Coil of PVC Speed Tubing (C)
 - 1 x Input Assembly (D)
 - 1 x Quick Connect Coupling (E)

18 Cell Stealth Watering System™ Kit
for 36 Volt Batteries

Stealth valve With
End Plug (B)

Stealth valves (A)

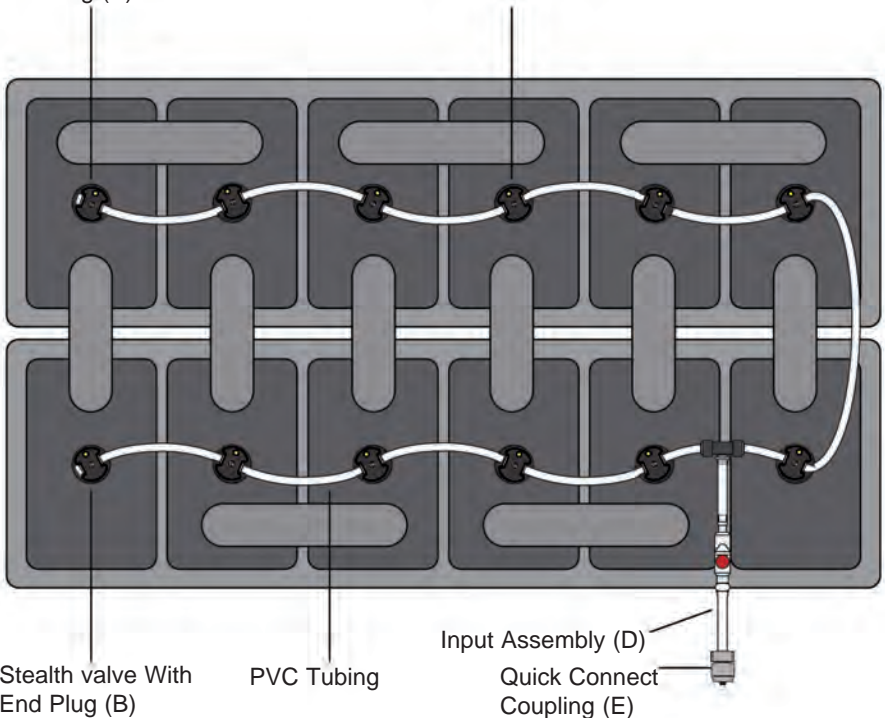

Stealth valve With
End Plug (B)

PVC Tubing

Input Assembly (D)

Quick Connect
Coupling (E)

Installation:

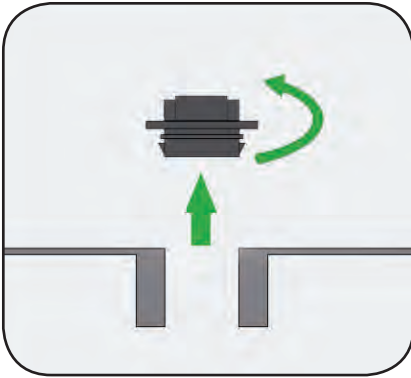

Remove the vent caps from each battery cell.

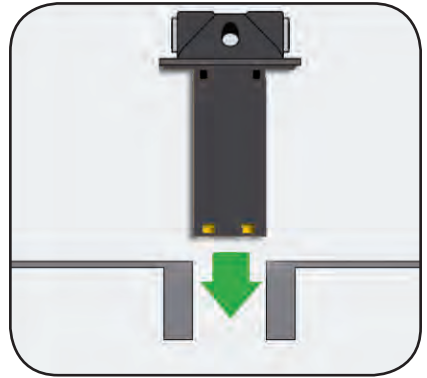

Place a Stealth valve into the vent hole of each battery cell and press firmly into place.

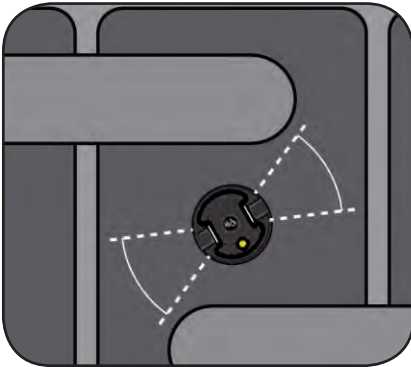

Ensure there is clear access to both of the valve's tubing ports.

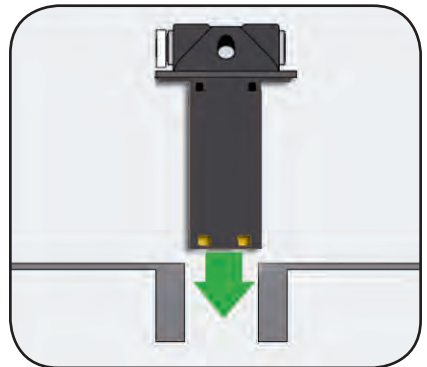

Locate the Stealth valves with end plugs next to the lugs.

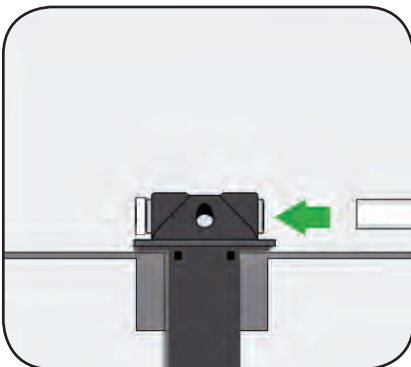

Fully insert the free end of the PVC Tubing in the first valve and push firmly until it stops.

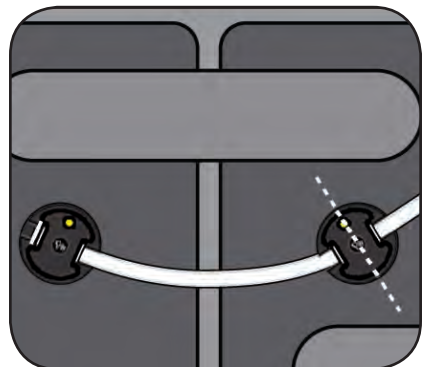

Measure the tubing to the middle of next valve in the sequence, ensuring a small amount of slack.

Installation (continued):

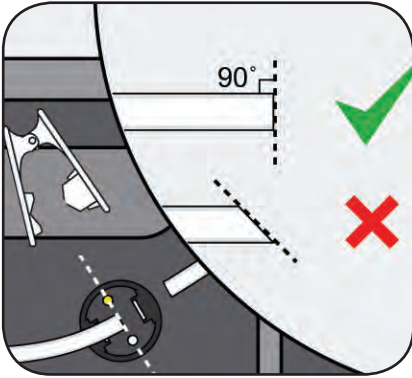

Cut the tubing squarely at this point using a tubing cutter ensuring end of tubing is not crushed.

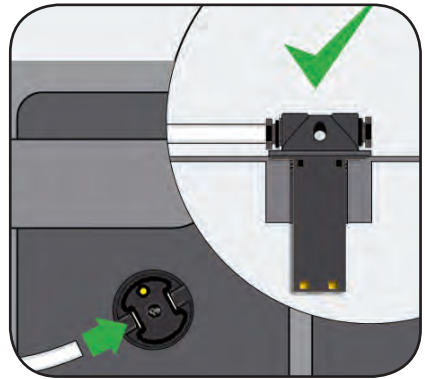

Insert the cut end of the tube in to the second valve and press firmly.

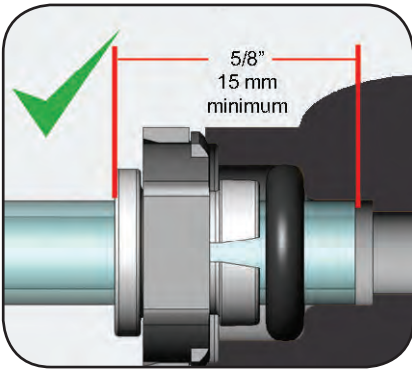

The PVC tubing must be cut squarely and fully inserted into each valve or it will leak.

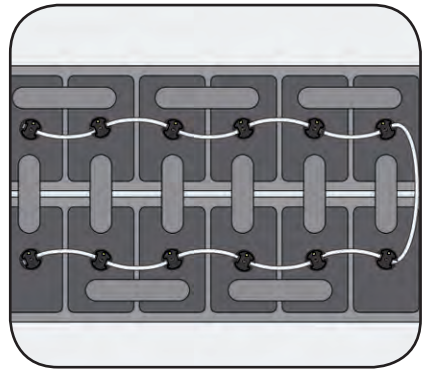

With the remaining tubing securely connect all of the valves together in the same way.

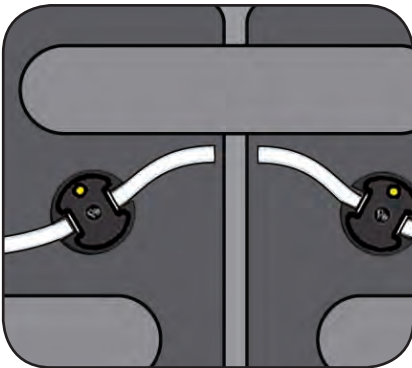

Once the tubing is fitted, choose a suitable position for the Water Input Assembly & cut the tubing.

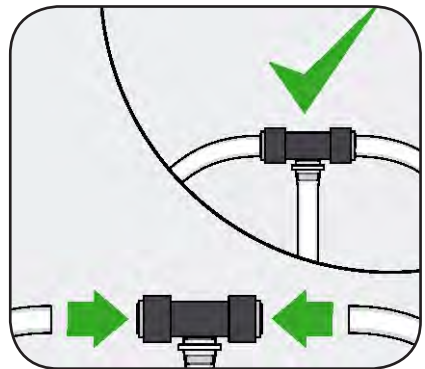

Fix the Water Input Assembly by firmly inserting the tube in the same way as with the valves.

Operation:

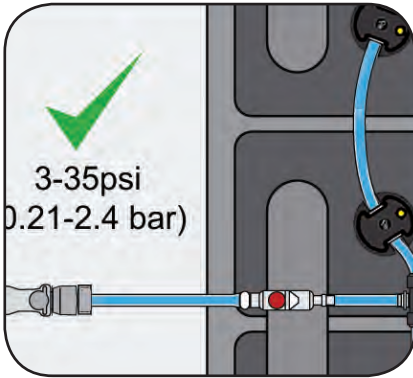

Working pressure is between 3-35psi (0.21-2.4 bar).

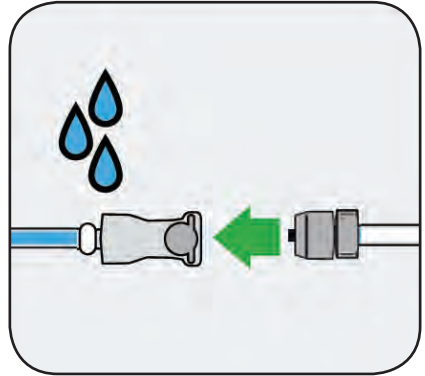

Connect the quick-connect fitting to a suitable water supply.

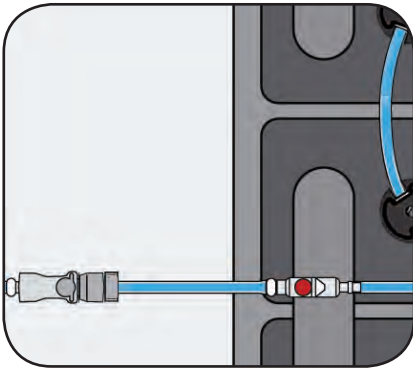

Filling will begin as soon as the connection is made (filling method dependent).

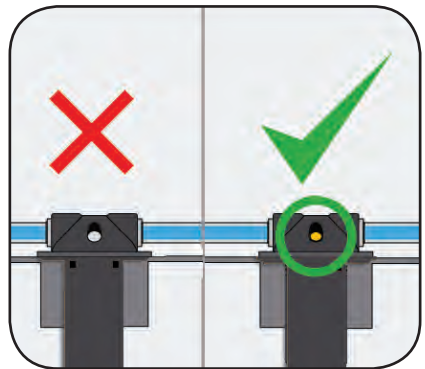

When all of the valves' fill level indicators are up the spinner on the Stealth water supply will stop.

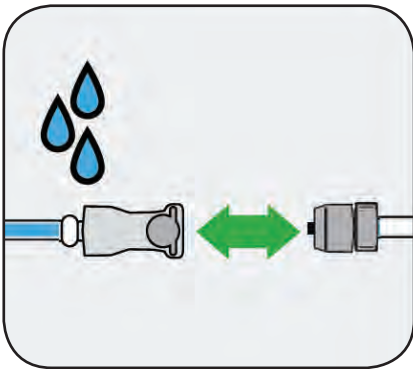

Once filling is complete disconnect the quick-connect.

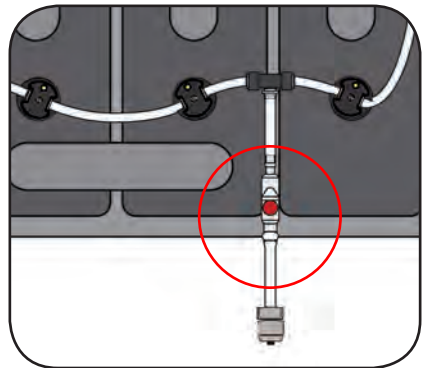

The filter traps impurities before they enter the Stealth valve and your battery. If the filter is visually clogged or fill-time become longer, change the filter. Part ID FLT-020

Sample 12-Cell Layout

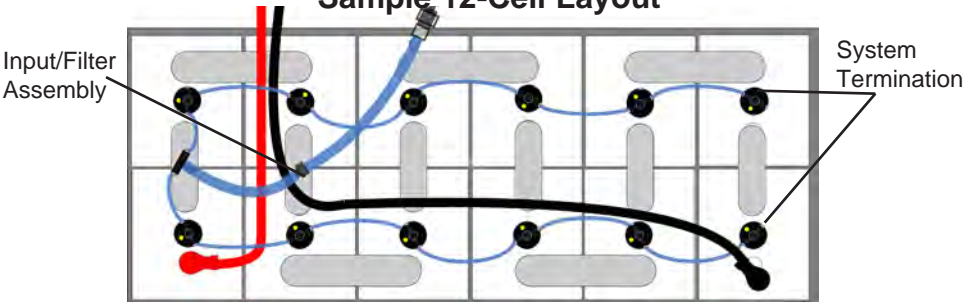

Sample 18-Cell Layout

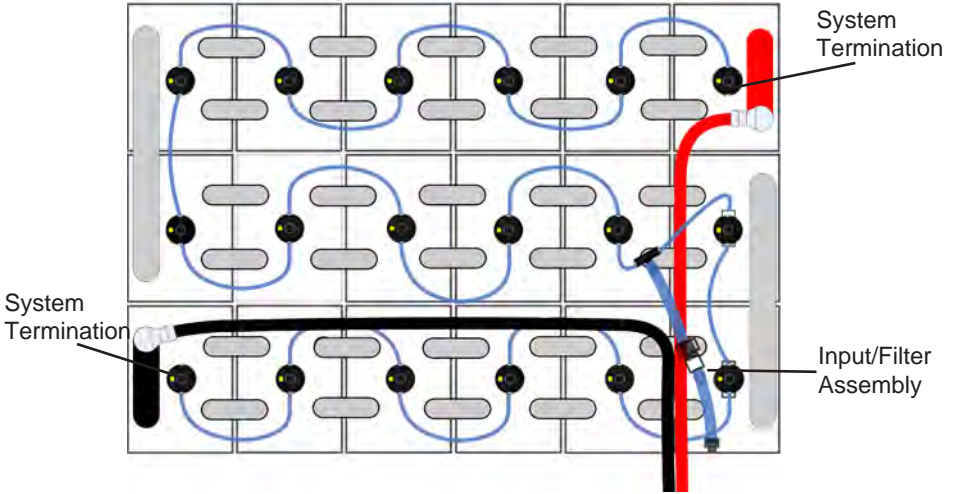

Sample 24-Cell Layout

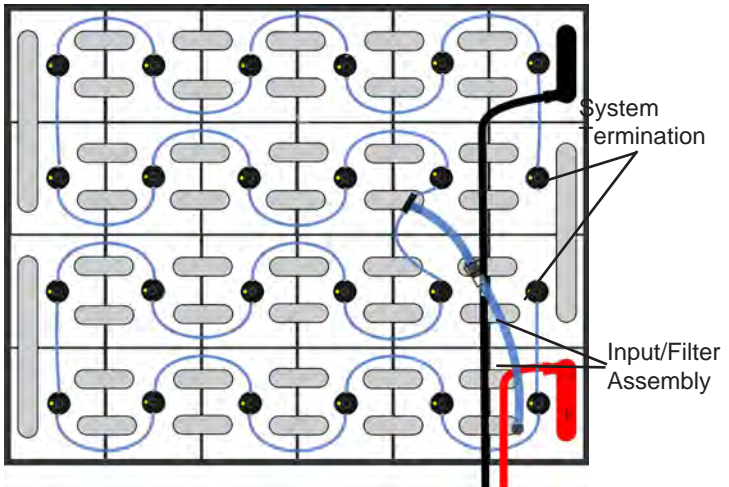

Installation (continued):

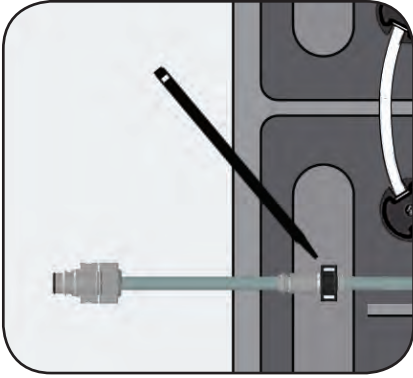

Secure the filter (Input assembly) to an inter-cell connector.

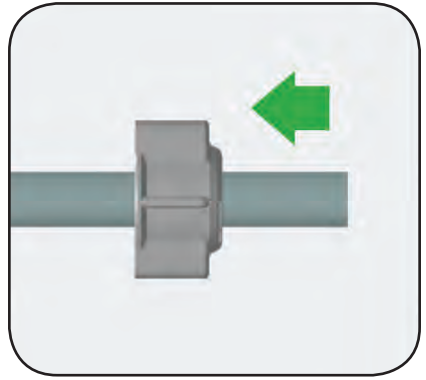

Slide the twist lock ring onto the free end of the Water Input Assembly.

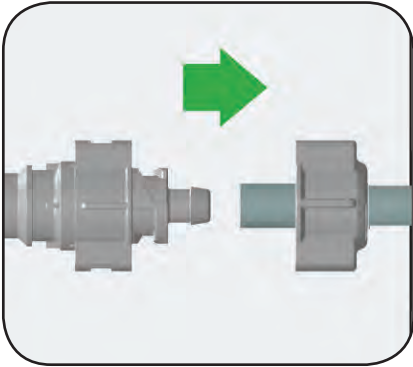

Insert the barb fitting of male quick connect fitting into the tubing.

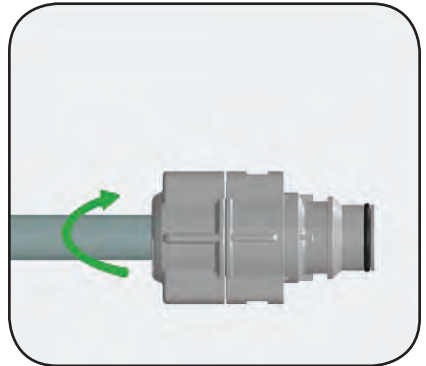

Push twist-lock ring and quick connect together & twist to lock onto the tubing.

Installation Note:

The standard Stealth Valve may not fit into Exide Technologies/GNB flat-plate Batteries or Crown MaxHaul because of the internal construction of these cells. For either of these batteries use the Stealth Slim. Due to the reduced shut off force of the narrow float Stealth Slim is not recommended for use in battery with wider openings. Use standard Stealth Watering System whenever possible.



Valve Removal:

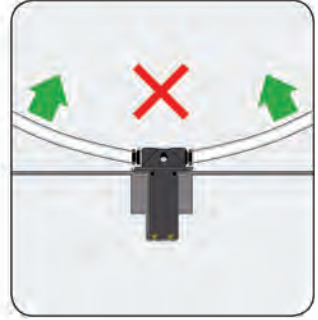
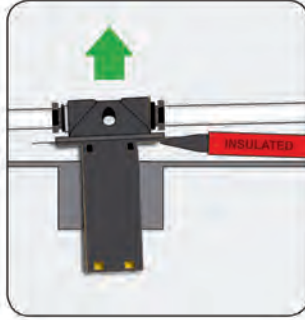
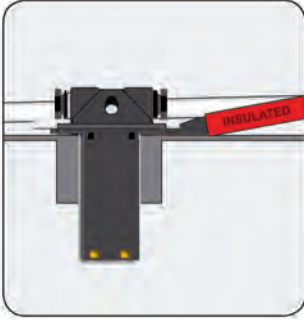

To remove a valve, insert an insulated screwdriver (or similar) under the lip of the valve.

Gently pry the valve out by levering around the lip.

Do not try to remove the valve by pulling on the tubing.

Let your batteries tell you when they need watering!

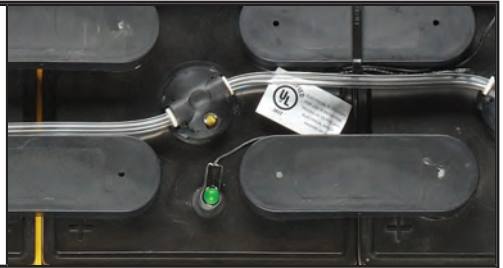

For complete battery maintenance performance, include an Electrolyte Monitor, The Philadelphia Scientific UL Classified Blinky™.

© 2015 Philadelphia Scientific LLC. All Rights Reserved. Philadelphia Scientific and the PS logo are registered trademarks of Philadelphia Scientific. Stealth Watering System, Stealth Slim and Blinky are trademarks of Philadelphia Scientific LLC. MaxHaul is a trademark of Crown Battery Mfg. Company. Exide/GNB is a registered trademark of Exide Technologies. E.&O.E.

Philadelphia Scientific LLC 207 Progress Drive Montgomeryville, PA 18936
P: 215.616.0390 F: 215.616.0500 www.phlsci.com